

167

FOR OFFICIAL USE.

(698)

III (4) A

WEIGHTS AND MEASURES ACT, 1904.

NOTICE OF EXAMINATION OF PATTERN No. 698.

**SUBMITTED BY HARDOLL, LTD., QUEEN'S PARK WORKS,
111, SALUSBURY ROAD, LONDON, N.W.6.**

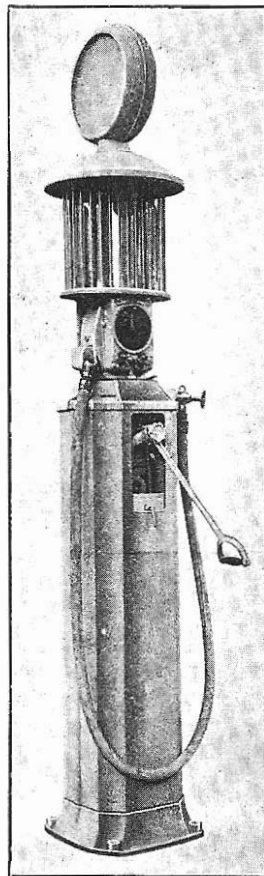

The Board of Trade have examined and tested, with reference to the material of which and the principle on which it is constructed, a pattern of a liquid measuring instrument for delivering in quantities of 1 gallon of the form shown herein, which has been submitted to the Department under the provisions of Section 6 of the above-mentioned Act, and have issued a Certificate No. 547 dated 22nd January, 1931, that the pattern is not such as to facilitate the perpetration of fraud when used for the measurement of petrol and other liquids of low viscosity.

Board of Trade, Standards Department,
Old Palace Yard, Westminster, S.W.1.
October, 1932.

53-9999.

[P.T.O.]

Crown Copyright Reserved

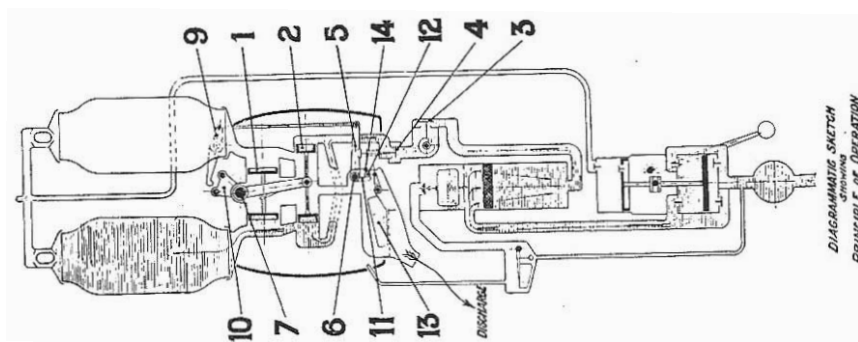
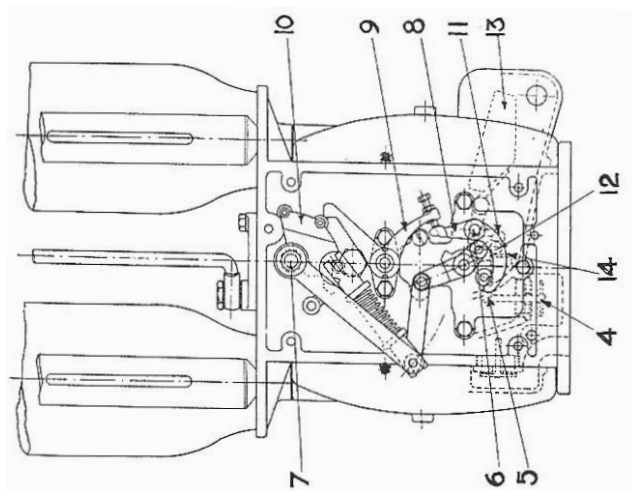
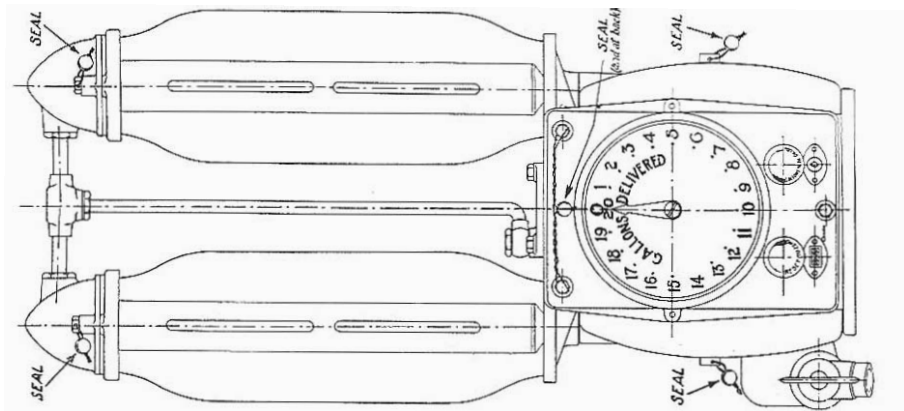

14425